



—
your partner
in sensor
technology.



User Manual EE850

CO₂, Humidity and Temperature
Duct Sensor



Content

1	General Information	3
1.1	Explanation of Warning Notices and Symbols	3
1.2	Safety Instructions	4
1.2.1.	General Safety Instructions	4
1.2.2.	Intended Use	4
1.2.3.	Mounting, Start-up and Operation	4
1.3	Environmental Aspects	5
2	Scope of Supply	5
3	Product Description	6
4	Mounting and Installation	6
5	Electrical Connection	7
6	Setup and Configuration	9
6.1	PCS10 Product Configuration Software	10
6.2	RS485 Digital Interface	10
6.2.1.	Hardware Bus Termination	10
6.2.2.	Device Address	11
6.2.3.	BACnet Protocol Settings	11
6.2.4.	Modbus RTU Protocol Settings	12
6.3	Modbus Register Map	13
6.4	Modbus RTU Example	14
7	Maintenance and Service	14
7.1	Calibration and Adjustment	14
7.1.1.	Definitions	14
7.1.2.	CO ₂ , T and RH Calibration and Adjustment	15
7.1.3.	Calibration and Adjustment at E+E Elektronik	15
7.1.4.	Calibration and Adjustment by the User	15
7.2	Repairs	16
8	Accessories	16
9	Technical Data	16
10	Conformity	18
10.1	Declarations of Conformity	18
10.2	FCC Part 15 Compliance Statement	18
10.3	ICES-003 Compliance Statement	18

1 General Information

This user manual serves for ensuring proper handling and optimal functioning of the device. The user manual shall be read before commissioning the equipment and it shall be provided to all staff involved in transport, installation, operation, maintenance and repair. E+E Elektronik Ges.m.b.H. does not accept warranty and liability claims neither upon this publication nor in case of improper treatment of the described products.

All information, technical data and diagrams included in this document are based on the information available at the time of writing. It may contain technical inaccuracies and typographical errors. The contents will be revised on a regular basis and changes will be implemented in subsequent versions. The described product(s) and the contents of this document may be changed or improved at any time without prior notice.

All rights reserved by E+E Elektronik Ges.m.b.H. No part of this document may be reproduced, published or publicly displayed in any form or by any means, nor may its contents be modified, translated, adapted, sold or disclosed to a third party without prior written permission of E+E Elektronik Ges.m.b.H.

PLEASE NOTE

Find this document and further product information on our website at www.epluse.com/ee850.

1.1 Explanation of Warning Notices and Symbols

Safety precautions

Precautionary statements warn of hazards in handling the device and provide information on their prevention. The safety instruction labeling is classified by hazard severity and is divided into the following groups:

DANGER

Danger indicates hazards for persons. If the safety instruction marked in this way is not followed, the hazard will very likely result in severe injury or death.

WARNING

Warning indicates hazards for persons. If the safety instruction marked in this way is not followed, there is a risk of injury or death.

CAUTION

Caution indicates hazards for persons. If the safety instruction marked in this way is not followed, minor or moderate injuries may occur.

NOTICE

Notice signals danger to objects or data. If the notice is not observed, damage to property or data may occur.

Informational notes

Informational notes provide important information which stands out due to its relevance.

INFO

The information symbol indicates tips on handling the device or provides additional information on it. The information is useful for reaching optimal performance of the device.

The title field can deviate from "INFO" depending on the context. For instance, it may also read "PLEASE NOTE".

1.2 Safety Instructions

1.2.1. General Safety Instructions

NOTICE

Improper handling of the device may result in its damage.

- The EE850 enclosure, the sensing probe and the sensing module shall not be exposed to unnecessary mechanical stress.
- The device shall not be exposed to extreme thermal stress.
- Use the EE850 only as intended and observe all technical specifications.

1.2.2. Intended Use

The EE850 is intended for CO₂, humidity (RH) and temperature (T) measurement in ducts. Its typical application is in demand controlled ventilation and building automation. Due to its wide measuring ranges and its insensitiveness to pollution, the EE850 can be employed in demanding climate and process control as well.

WARNING

Non-compliance with the product documentation may cause safety risks for people and the entire measurement installation.

The manufacturer cannot be held responsible for damages as a result of incorrect handling, installation and maintenance of the device.

- Do not use EE850 in explosive atmosphere or for measurement in aggressive gases.
- This device is not appropriate for safety, emergency stop or other critical applications where device malfunction or failure could cause injury to human beings.
- The device may not be manipulated with tools other than specifically described in this manual.

NOTICE

Failing to follow the instructions in this user manual may lead to measurement inaccuracy and device failures.

- The EE850 may only be used under the conditions defined in chapter 9 Technical Data. Otherwise, measurement inaccuracies may occur and device failures cannot be ruled out.
- The steps recommended by the manufacturer for installation, inspections and maintenance work must be observed and carried out for the safety of the user and for the functionality of the equipment.
- Unauthorized product modification leads to loss of all warranty claims. Modification may be accomplished only with an explicit permission of E+E Elektronik Ges.m.b.H.!

1.2.3. Mounting, Start-up and Operation

The EE850 duct sensor has been produced under state of the art manufacturing conditions, has been thoroughly tested and has left the factory after fulfilling all safety criteria. The manufacturer has taken all precautions to ensure safe operation of the device. The user must ensure that the device is set up and installed in a way that does not impair its safe use. The user is responsible for observing all applicable local and international safety guidelines for safe installation and operation of the device. This user manual contains information and warnings that must be observed by the user in order to ensure safe operation.

PLEASE NOTE

The manufacturer or his authorized agent can only be held liable in case of willful or gross negligence. In any case, the scope of liability is limited to the corresponding amount of the order issued to the manufacturer. The manufacturer assumes no liability for damages incurred due to failure to comply with the applicable regulations, operating instructions or the specified operating conditions. Consequential damages are excluded from the liability.

This manual contains information and notes of caution, which have to be followed by the user to assure safe operation.

WARNING

Non-compliance with the product documentation may cause accidents, personal injury or property damage.

- Mounting, electrical installation, commissioning, start-up, operation and maintenance of the device may be performed by qualified staff only. Such staff must be authorized by the operator of the facility to carry out the mentioned activities.
- The qualified staff must have read and understood this user manual and must follow the instructions contained within. The manufacturer accepts no responsibility for non-compliance with instructions, recommendations and warnings.
- All process and electrical connections shall be thoroughly checked by authorized staff before putting the device into operation.
- Do not install or start-up a device supposed to be faulty. Make sure that such devices are not used accidentally by marking them clearly as faulty.
- A faulty device may only be investigated and possibly repaired by qualified, trained and authorized staff. If the fault cannot be fixed, the device shall be removed from the process.
- Service operations other than described in this user manual may only be performed by the manufacturer.

1.3 Environmental Aspects

PLEASE NOTE

Products from E+E Elektronik Ges.m.b.H. are developed and manufactured in compliance with all relevant environmental protection requirements. Please observe local regulations for the disposal of the device.



For disposal, the individual components of the device must be separated according to local recycling regulations. The electronics shall be disposed of correctly as electronics waste.

2 Scope of Supply

- EE850 sensor according ordering guide
- Cable gland
- Mounting set with flange
- Test report according to DIN EN10204-2.2
- Quick guide (for digital version)

3 Product Description

The EE850 CO₂ sensor accurately measures CO₂, relative humidity (RH) and temperature (T) in demand controlled ventilation, process control and building automation. Measuring ranges are up to 10 000 ppm (CO₂) and -20...+60 °C (-4...+140 °F) (T).

The sensor is available with two probe lengths and analogue and digital outputs. The analogue current or voltage outputs provide the measured values as well as the calculated value for the dew point temperature (Td). The RS485 interface with Modbus RTU or BACnet MS/TP protocol also supplies other calculated parameters such as absolute humidity (dv), mixing ratio (r), water vapour partial pressure (e) or enthalpy (h).

The EE850 can be configured with the PCS10 Product Configuration Software. For details, please refer to chapter 6 Setup and Configuration.

4 Mounting and Installation

Values in mm / inch

Enclosure

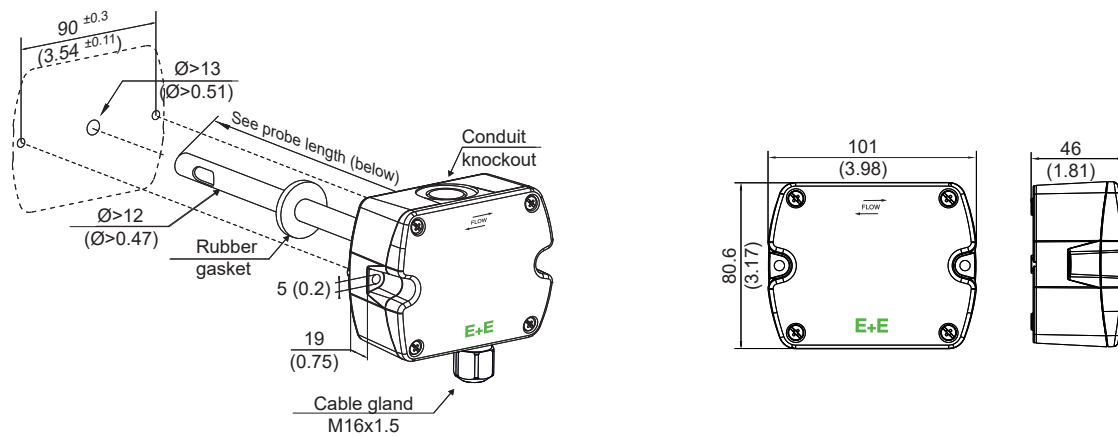

Mounting Flange

(Included in the scope of supply)

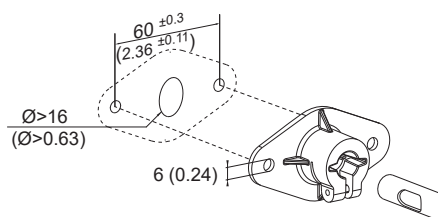

Recommended mounting screws:
ST4.2x50 DIN 7981 C

Probe length

L200:

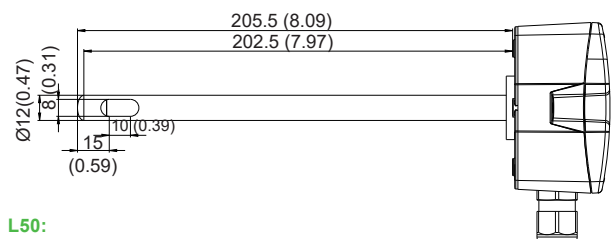

L50:

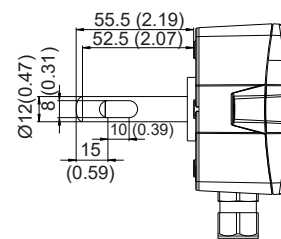

Installed into a duct, a small amount of air flows through the divided probe into the EE850 enclosure, where the CO₂ sensing cell is located, and back into the duct. The RH and T sensing elements are placed inside the probe.

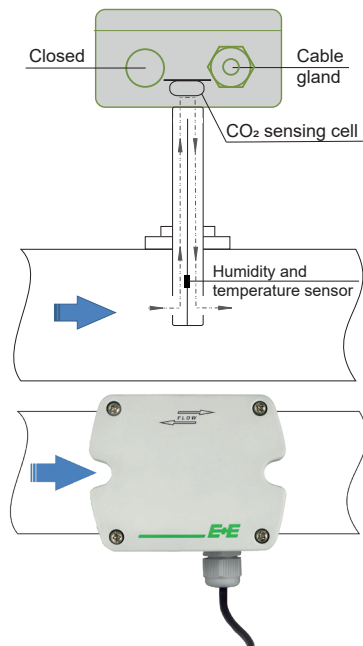

Fig. 1 EE850 measurement principle

NOTICE

False air ingress may lead to measurement inaccuracy and device failures.

For accurate measurement, both the cover of the EE850 and the cable outlet – cable gland or conduit adapter – must be closed tightly. This is essential for avoiding ingress of air other than from the duct into the EE850 enclosure, which would falsify the measurement.

i PLEASE NOTE

The direction of air flow in the duct shall correspond to the direction indicated with arrows on the EE850 cover. Depending on the EE850 version, the response time specified is only valid for direction marked with the blue arrow with respect to the cable gland position.

EE850 with conduit connection for the North American market: use a flat screwdriver to carefully break open the plastic knockout at the marked location, in order to avoid damaging the electronics inside the enclosure. The conduit adapter is not included in the scope of supply.

5 Electrical Connection

EE850 features screw terminals for connecting the power supply and the outputs. The cables are fed into the enclosure through the M16 cable gland.

NOTICE

It is important to make sure that the cable glands are closed tightly for the power supply and outputs cable. This is necessary for assuring the IP rating of the enclosure according to EE850 specification, as well as for stress relief at the screw terminals on the EE850 board.

⚠ WARNING

Incorrect installation, wiring or power supply may cause overheating and therefore personal injuries or damage to property.

For correct cabling of the device, always observe the presented wiring diagram for the product version used.

The manufacturer cannot be held responsible for personal injuries or damage to property as a result of incorrect handling, installation, wiring, power supply and maintenance of the device.

EE850-M10 and EE850-M11

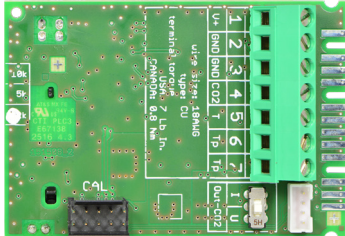

EE850-M10 / voltage output

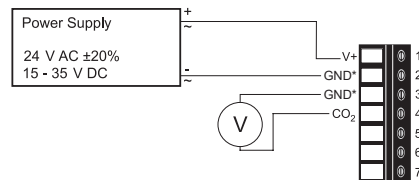

EE850-M10 / current output

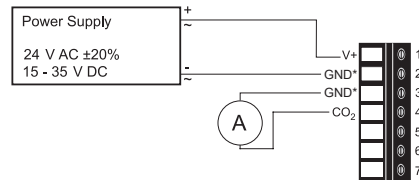

EE850-M11 / voltage output

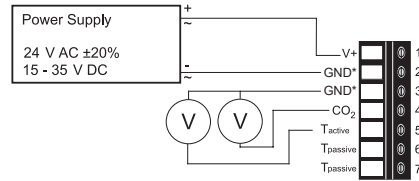

EE850-M12

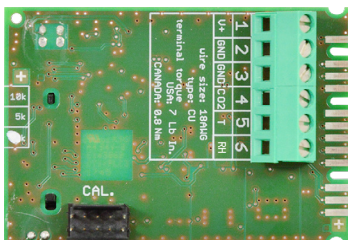

EE850-M12 / voltage output

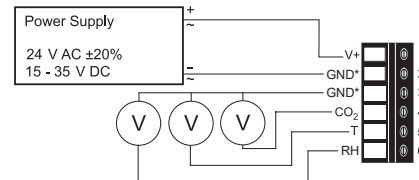

NOTICE

*For failure-free operation and performance according to the specs the supply GND and the measurement GND must be wired separately.

EE850-M1xJ3

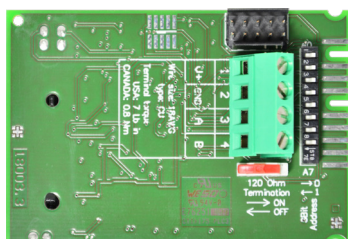

EE850-M1xJ3 / digital output

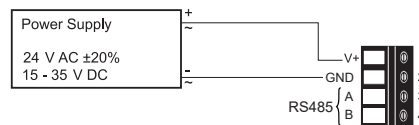

Fig. 2 EE850 connection options

6 Setup and Configuration

The EE850 is ready to use and does not require any configuration by the user. The factory setup of EE850 corresponds to the type number ordered. Please refer to the datasheet at www.epluse.com/ee850.

If required, the user can change the factory setup with the help of the free PCS10 Product Configuration Software and the USB configuration adapter (HA011066). The CO₂ output signal and output scaling can be changed and CO₂, RH and T adjustment/calibration can be performed.

NOTICE

The EE850 may not be connected to any additional power supply when using the USB configuration adapter HA011066.

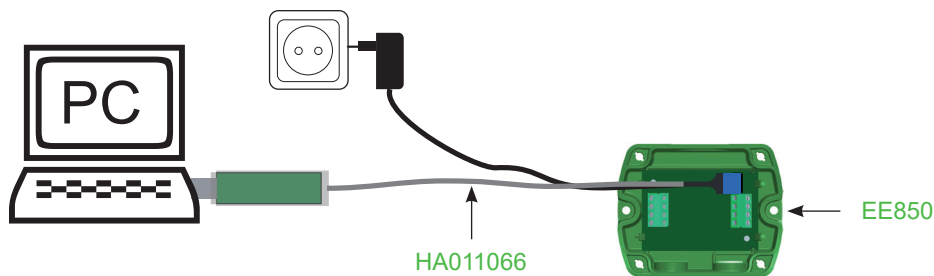

Fig. 3 EE850 connected to a PC running PCS10

Model EE850-M10:

Select the CO₂ output signal:

The output signal can be changed from voltage to current or vice-versa. Set the output signal selection switch to I for current 4 - 20 mA output or to U for voltage 0 - 10 V output. The original CO₂ output range does not change and the calibration data remains valid.

The scaling of the output can be changed by using USB Configuration Adapter (HA011066) and Product Configuration Software (PCS10).

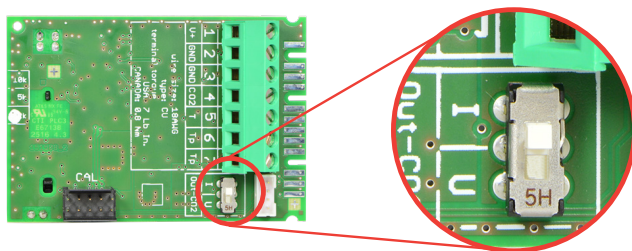

Fig. 4 Model EE850-M10 – Selector switch for the output signal

Example:

Factory setup: voltage output (U), output scale: 0 - 10 V = 0...10 000 ppm.

User setup (after setting the output signal selection switch to I): current output (I), output scale: 4 - 20 mA = 0...10 000 ppm.

Model EE850-M11 and EE850-M12:

Changing the CO₂ and T output scale:

The scaling of the output can be changed by using USB Configuration Adapter (HA011066) and Product Configuration Software (PCS10).

Example:

The initial scaling of the outputs		The output scale after the change	
CO ₂	0 - 10 V = 0...10 000 ppm	CO ₂	0 - 10 V = 400...8 000 ppm
T	0 - 10 V = 0...50 °C	T	0 - 10 V = 40...100 °F
RH	0 - 10 V = 0...100 %RH	Td	0 - 10 V = -20...+40 °C

i PLEASE NOTE

- After changing the factory setup (output signal and/or output scale) the original type number on the EE850 identification label loses its validity; it does not match any longer the device setup.
- The return to factory setup function of PCS10 restores the original adjustment/calibration of the device, but does not affect the user setup for output signal and output scale.

6.1 PCS10 Product Configuration Software

To use the software for changes in settings, please proceed as follows:

1. Download the PCS10 Product Configuration Software from www.epluse.com/pcs10 and install it on the PC.
2. Connect the EE850 to the PC using the Modbus configuration adapter.
3. Start the PCS10 software.
4. Follow the instructions on the PCS10 opening page for scanning the ports and identifying the connected device
5. Click on the desired setup mode from the main PCS10 menu on the left. Follow the online instructions of the PCS10 which are displayed when clicking the "Tutorial" button.
6. Changes are uploaded to the sensor by pressing the "Sync" button.

6.2 RS485 Digital Interface

6.2.1. Hardware Bus Termination

For bus termination EE850 features an internal 120 Ω resistor which can be activated using the slide switch on the electronics board (see also chapter 5 Electrical Connection for details).

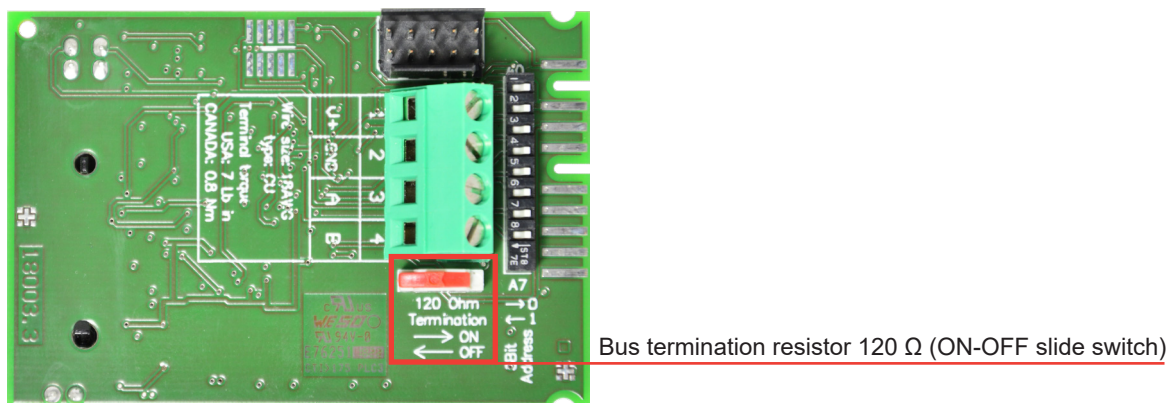

Fig. 5 Model EE850-M1xJ3 – Selector switch for the bus termination

NOTICE

For proper function, the power supply must be strong enough to ensure supply voltage within the specified range (see 9 Technical Data) at any time and at all devices in the bus. This is particularly relevant when using long and thin cables which can cause high voltage drop. Please note that a single digital EE850 requires peak current of 150 mA.

6.2.2. Device Address

Address Switch

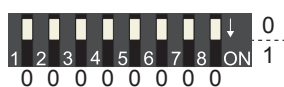

Address setting via PCS10 Product Configuration Software

All DIP switches at position 0 → address has to be set via PCS10

Modbus (slave device): factory setting 67 (permitted values: 1...247).

BACnet (master device): factory setting 67 (permitted values: 0...127).

Example: Address is set via configuration software = factory setting.

Address Switch



Address setting via DIP switch

Modbus (slave device): Setting the DIP switches to any other address than 0, overrules the Modbus address set via PCS10 (permitted values: 1...247).

BACnet (master device): Setting the DIP switches to any other address than 0, overrules the BACnet address set via configuration software.

BACnet Note: permitted values are 0...127. The 8th bit of the DIP switches is ignored (ID 127 = 0111 111). To set address 0 via DIP switches, the 8th bit shall be set to 1 (ID 0 = 1000 0000).

Example: Address set to 11 (= 0000 1011 binary).

6.2.3. BACnet Protocol Settings

	Factory settings	Selectable values (via PCS10)
Baud rate	As ordered via order code	9 600, 19 200, 38 400, 57 600, 76 800, 115 200
Data bits	8	8
Parity	None	None
Stop bits	1	1
BACnet address	67	0...127

Tab. 1 BACnet protocol settings

i PLEASE NOTE

- The recommended settings for multiple devices in a BACnet MS/TP network are 38400, 8, None, 1.
- The EE850 represents 1/10 unit load on an RS485 network.

The EE850 PICS (Product Implementation Conformance Statement) is available on the E+E website at www.epluse.com/ee850.

BACnet address and baud rate can be set via:

- PCS10 Product Configuration Software and the USB configuration adapter HA011066. The PCS10 can be downloaded free of charge from www.epluse.com/pcs10.
- BACnet protocol, see the PICS.

6.2.4. Modbus RTU Protocol Settings

	Factory settings	Selectable values (via PCS10)
Baud rate	As ordered via order code	9 600, 19 200, 38 400, 57 600, 76 800, 115 200
Data bits	8	8
Parity	Even	None, odd, even
Stop bits	1	1, 2
Modbus address	67	1...247

Tab. 2 Modbus RTU protocol settings

i PLEASE NOTE

- The recommended settings for multiple devices in a Modbus RTU network are 9600, 8, even, 1.
- The EE850 represents 1/10 unit load on an RS485 network.

Device address, baud rate, parity and stop bits can be set via:

- PCS10 Product Configuration Software and the USB configuration adapter HA011066.
The PCS10 can be downloaded free of charge from www.epluse.com/pcs10.
- Modbus protocol in the register 1 (0x00) and 2 (0x01).
See Application Note Modbus AN0103 (available at www.epluse.com/ee850).

The serial number as ASCII-code is located in read-only registers 1 - 8 (0x00 - 0x07).

The firmware version is located in register 9 (0x08) (bit 15...8 = major release; bit 7...0 = minor release).

The sensor name as ASCII-code is located in read-only registers 10 - 17 (0x09 - 0x11).

NOTICE

When reading information that spans multiple registers, it is always necessary to read all registers, even if the desired information requires less.

NOTICE

For obtaining the correct floating point values, both registers have to be read within the same reading cycle. The measured value can change between two Modbus requests, exponent and mantissa may get inconsistent then.

Communication settings (INT16)

Parameter	Register number ¹⁾ [Dec]	Register address ²⁾ [Hex]	Size ³⁾
Write register: function code 0x06			
Modbus address ⁴⁾	1	00	1
Modbus protocol settings ⁴⁾	2	01	1

Device information (INT16)

Parameter	Register number ¹⁾ [Dec]	Register address ²⁾ [Hex]	Size ³⁾
Read register: function code 0x03 / 0x04			
Serial number (as ASCII)	1	00	8
Firmware version	9	08	1
Sensor name	10	09	8

1) Register number (decimal) starts from 1.

2) Register address (hexadecimal) starts from 0.

3) Number of registers.

4) For Modbus address and protocol settings see Application Note Modbus AN0103 (available at www.epluse.com/ee850).

Tab. 3 EE850 registers for device setup

6.3 Modbus Register Map

The measured data is saved as 32 bit floating point values (data type FLOAT32) and as 16 bit signed integer values (data type INT16).

FLOAT32

Parameter	Unit	Register number ¹⁾ [DEC]	Register address ²⁾ [HEX]
Read register: function code 0x03 / 0x04			
Temperature	°C	1003	3EA
	°F	1005	3EC
Relative humidity	%	1021	3FC
CO ₂ (average)	ppm	1061	424
CO ₂ (raw)	ppm	1063	426
Water vapour partial pressure	mbar	1101	44C
	psi	1103	44E
Dew point temperature	°C	1105	450
	°F	1107	452
Absolute humidity	g/m ³	1113	458
	gr/ft ³	1115	45A
Mixing ratio	g/kg	1121	460
	gr/lb	1123	462
Specific enthalpy	kJ/kg	1125	464
	ft lb/lb	1127	466
	BTU/lb	1129	468
Frost point temperature	°C	1131	46A
	°F	1133	46C

INT16

Parameter	Unit	Scale ³⁾	Register number ¹⁾ [DEC]	Register address ²⁾ [HEX]
Read register: function code 0x03 / 0x04				
Temperature	°C	100	4002	FA1
	°F	50	4003	FA2
Relative humidity	%	100	4011	FAA
CO ₂ (average)	ppm	1	4031	FBE
CO ₂ (raw)	ppm	1	4032	FBF
Water vapour partial pressure	mbar	10	4051	FD2
	psi	1000	4052	FD3
Dew point temperature	°C	100	4053	FD4
	°F	100	4054	FD5
Absolute humidity	g/m ³	10	4057	FD8
	gr/ft ³	10	4058	FD9
Mixing ratio	g/kg	10	4061	FDC
	gr/lb	10	4062	FDD
Specific enthalpy	kJ/kg	1	4063	FDE
	ft lb/lb	1	4064	FDG
	BTU/lb	1	4065	FE0
Frost point temperature	°C	100	4066	FE1
	°F	100	4067	FE2

1) Register number (decimal) starts from 1.

2) Register address (hexadecimal) starts from 0.

3) Examples for factory scaling of stored value

100	is the scale 1:100	(e.g. 2550 is equivalent to 25.5 °C)
50	is the scale 1:50	(e.g.: 2550 is equivalent to 51 °F)
10	is the scale 1:10	(e.g.: 135 is equivalent to 13.5 mbar)
1	is the scale 1:1	(e.g.: 800 is equivalent to 800 ppm)

Tab. 4 EE850 FLOAT32 and INT16 measured data registers

6.4 Modbus RTU Example

The EE850's Modbus address is 67 [0x43].

Please refer to

Tab. 5 MODBUS APPLICATION PROTOCOL SPECIFICATION V1.1b3, chapter 6:
www.modbus.org/docs/Modbus_Application_Protocol_V1_1b3.pdf

- E+E Application Note Modbus AN0103 (available at www.epluse.com/ee850)

Read the CO₂ concentration (FLOAT32) CO₂ = 1288.34375 ppm from the register 0x424:

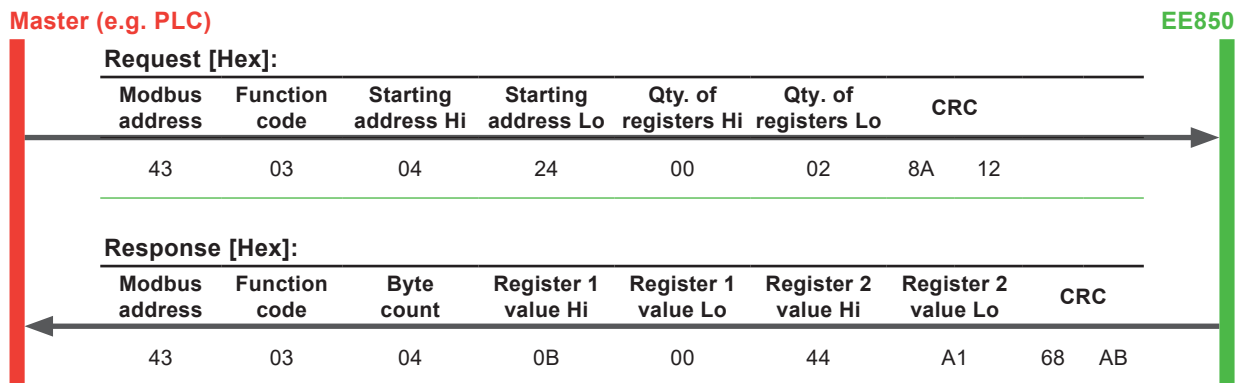

Tab. 6 Example temperature query

Decoding of floating point values:

Floating point values are stored according to IEEE754. The byte pairs 1, 2 and 3, 4 are transformed as follows (numbers taken from CO₂ reading Modbus request/response example above):

Modbus response [Hex]			
Byte 3 (Register 1 - Hi)	Byte 4 (Register 1 - Lo)	Byte 1 (Register 2 - Hi)	Byte 2 (Register 2 - Lo)
0B	00	44	A1
MMMM MMMM	MMMM MMMM	SEEE EEEE	EMMM MMMM

Tab. 7 Modbus response

IEEE754			
Byte 1	Byte 2	Byte 3	Byte 4
44	A1	0B	00
0100 0100	1010 0001	0000 1011	0000 0000
SEEE EEEE	EMMM MMMM	MMMM MMMM	MMMM MMMM
Decimal value: 1288.34375			

Tab. 8 Data representation according to IEEE754

7 Maintenance and Service

7.1 Calibration and Adjustment

7.1.1. Definitions

Calibration: The specimen is compared with a reference and its deviation from the reference is documented.

Adjustment: The specimen is brought in line with the reference.

7.1.2. CO₂, T and RH Calibration and Adjustment

Depending on the application and the requirements of certain industries, there might arise the need for periodical CO₂, temperature and RH calibration or adjustment.

7.1.3. Calibration and Adjustment at E+E Elektronik

Calibration and / or adjustment can be performed in the E+E Elektronik calibration laboratory. For information on the E+E capabilities in ISO or accredited calibration please see www.eplusecal.com.

7.1.4. Calibration and Adjustment by the User

Perform offset and 1- or 2-point adjustment via the PCS10 Product Configuration Software (see below).

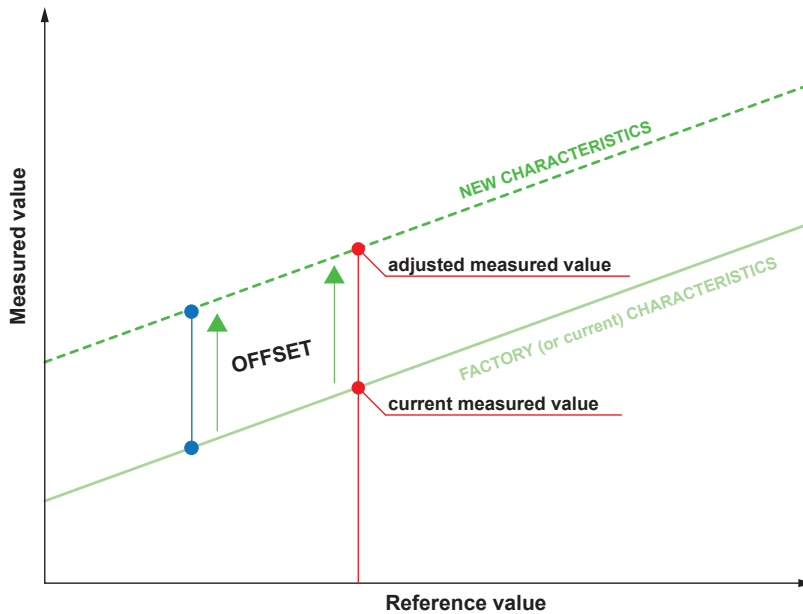

Fig. 6 Offset adjustment

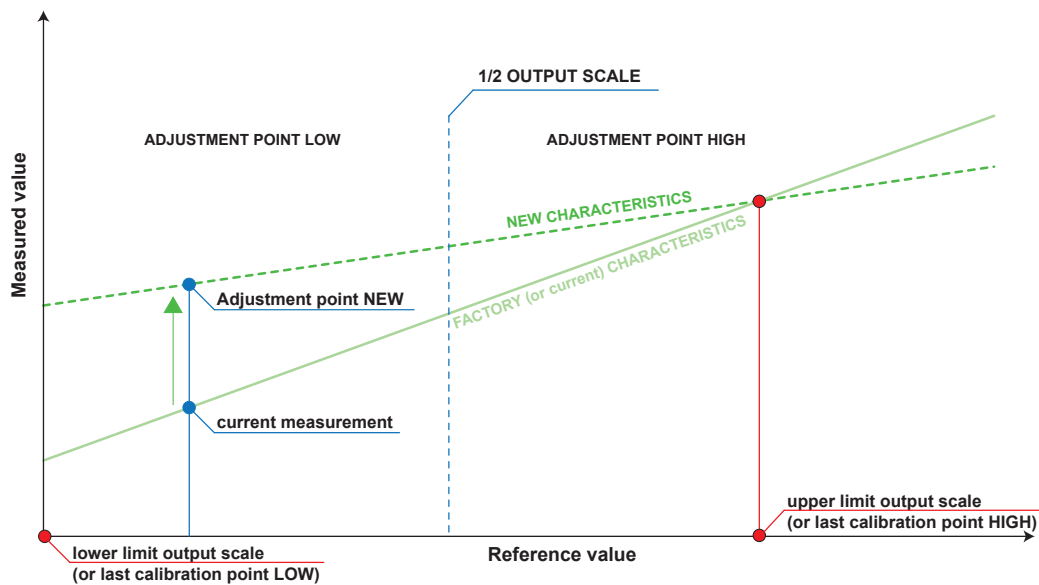

Fig. 7 1- or 2-point adjustment

7.2 Repairs

Repairs may be carried out by the manufacturer only. The attempt of unauthorized repair excludes any warranty claims.

8 Accessories

For further information see datasheet "[Accessories](#)".

Accessories	Code
Configuration adapter cable	HA011066
E+E Product configuration software (Free download: www.epluse.com/pcs10)	PCS10
Power supply adapter	V03

9 Technical Data

Measurands

CO₂

Measurement principle	Dual wavelength non-dispersive infrared technology (NDIR)
Measuring range	0...2 000 / 10 000 ppm
Accuracy @ 25 °C (77 °F) and 1 013 mbar (14.7 psi) 0...2 000 ppm 0...10 000 ppm	< ±(50 ppm +2 % of measured value) < ±(100 ppm +5 % of measured value)
Temperature dependency , typ. in the range of -20...+45 °C (-4...+113 °F)	±(1+ CO ₂ Konzentration [ppm] / 1 000) ppm/°C ± 0.556 * (1+ CO ₂ concentration [ppm] / 1 000) ppm/°F
Response time t ₆₃ , typ.	<100 s at 3 m/s (590 ft/min) air speed in the duct
Measuring interval	Approx. 15 s
Calibration interval Recommended under normal operating conditions in building automation.	>5 years

Temperature (T)

Measuring range	-20...+60 °C (-4...+140 °F)
Accuracy @ 20 °C (68 °F)	±0.3 °C (± 0.5 °F)
Response time t ₆₃	<50 s

Relative humidity (RH)

Measuring range	0...95 %RH
Accuracy @ 20 °C (68 °F)	±3 %RH (20...80 %RH)
Response time t ₆₃	<10 s

Outputs

Analogue

RH: 0...100 % T: according to ordering guide	0 - 10 V	-1 mA < I _L < 1 mA	I _L = load current
CO₂ 0...2 000 / 10 000 ppm	0 - 10 V 4 - 20 mA	-1 mA < I _L < 1 mA R _L < 500 Ω	R _L = load resistance



T sensor passive

2-wire-connection	T sensor type according ordering guide
Wire resistance (terminal - sensor), typ.	0.4 Ω

Digital

Digital Interface	RS485 (EE850 = 1/10 unit load)
Protocol Factory settings Supported Baud rates Measured data types	Modbus RTU 9 600 Baud, parity even, 1 stop bit, Modbus address 67 9 600, 19 200 und 38 400 FLOAT32 and INT16
Protocol Factory settings Supported Baud rates	BACnet MS/TP BACnet address 67 9 600, 19 200, 38 400, 57 600, 76 800 und 115 200

General

Power supply class III  USA & Canada: Class 2 supply necessary, max. voltage 30 V DC	24 V AC ±20 % 15 - 35 V DC
Current consumption, typ.	15 mA + output current
Peak current, max..	350 mA for 0.3 s (analogue output) 150 mA for 0.3 s (RS485 interface)
Minimum air speed in the duct, min.	1 m/s (196 ft/min)
Electrical connection	Screw terminals max. 2.5 mm ² (AWG 14)
Cable gland	M16x1.5
Working and storage conditions	-20...+60 °C (-4...+140 °F) 0...95 %RH, non-condensing
Enclosure material	Polycarbonate (PC), UL94 V-0 approved
Protection rating Enclosure Probe	IP65 / NEMA 4X IP20
Electromagnetic compatibility	EN 61326-1 EN 61326-2-3 Industrial environment FCC Part15 Class A ICES-003 Class A
Conformity	EN 45545-2 (HL3)  
Configuration and adjustment	PCS10 Product Configuration Software (free download) and configuration adapter

10 Conformity

10.1 Declarations of Conformity

E+E Elektronik Ges.m.b.H. hereby declares that the product complies with the respective regulations listed below:



European directives and standards.

and



UK statutory instruments and designated standards.

Please refer to the product page at www.epluse.com/ee850 for the Declarations of Conformity.

10.2 FCC Part 15 Compliance Statement

This equipment has been tested and found to comply with the limits for a Class A digital device, pursuant to part 15 of the FCC Rules. These limits are designed to provide reasonable protection against harmful interference when the equipment is operated in a commercial environment. This equipment generates, uses, and can radiate radio frequency energy and, if not installed and used in accordance with the instruction manual, may cause harmful interference to radio communications. Operation of this equipment in a residential area is likely to cause harmful interference in which case the user will be required to correct the interference at his own expense.

10.3 ICES-003 Compliance Statement

This Class A digital apparatus complies with Canadian ICES-003.

Cet appareil numérique de la classe A est conforme à la norme NMB-003 du Canada.

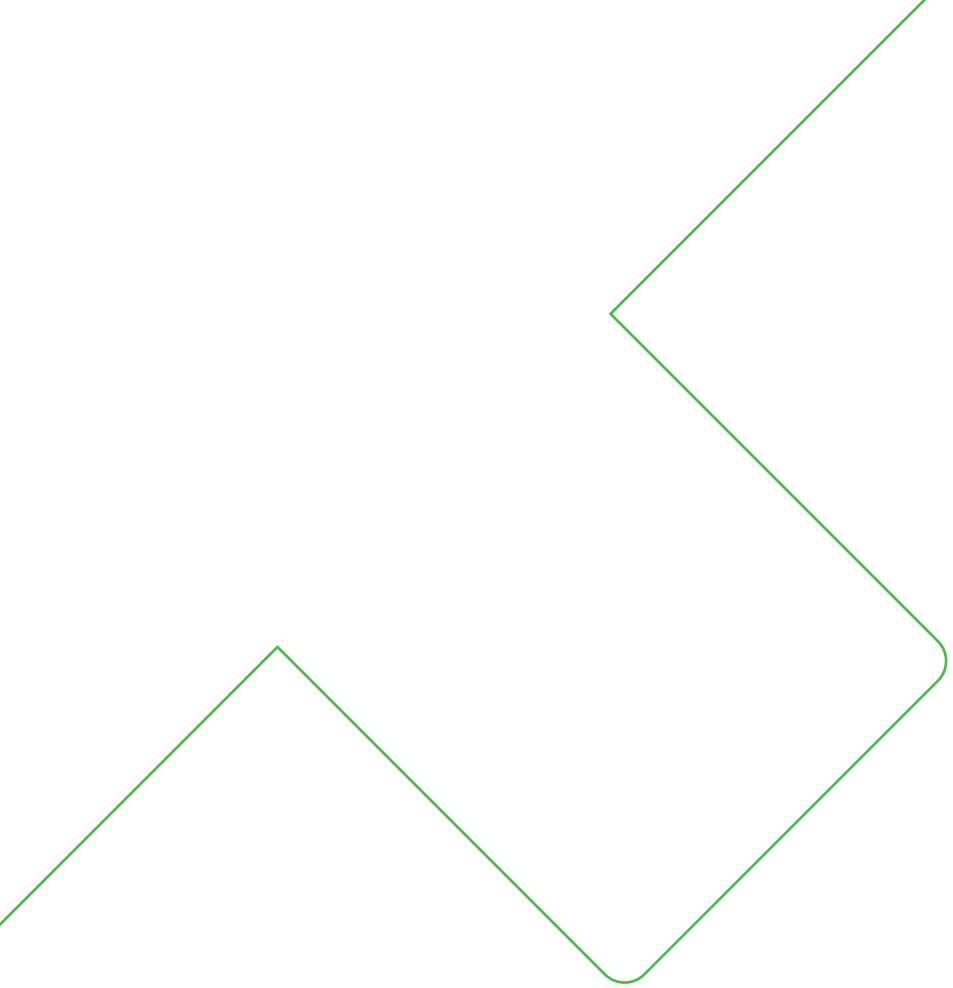

Company Headquarters &
Production Site

E+E Elektronik Ges.m.b.H.
Langwiesen 7
4209 Engerwitzdorf | Austria
T +43 7235 605-0
F +43 7235 605-8
info@epluse.com
www.epluse.com

Subsidiaries

E+E Sensor Technology (Shanghai) Co., Ltd.
T +86 21 6117 6129
info@epluse.cn

E+E Elektronik France SARL
T +33 4 74 72 35 82
info.fr@epluse.com

E+E Elektronik Deutschland GmbH
T +49 6171 69411-0
info.de@epluse.com

E+E Elektronik India Private Limited
T +91 990 440 5400
info.in@epluse.com

E+E Elektronik Italia S.R.L.
T +39 02 2707 86 36
info.it@epluse.com

E+E Elektronik Korea Ltd.
T +82 31 732 6050
info.kr@epluse.com

E+E Elektronik Corporation
T +1 847 490 0520
info.us@epluse.com



—
your partner
in sensor
technology.